

490/Al Series

Intermediate Movement Joints (Field Limitation Joints)

For use in
hospitals • airports • shopping malls • exhibition halls

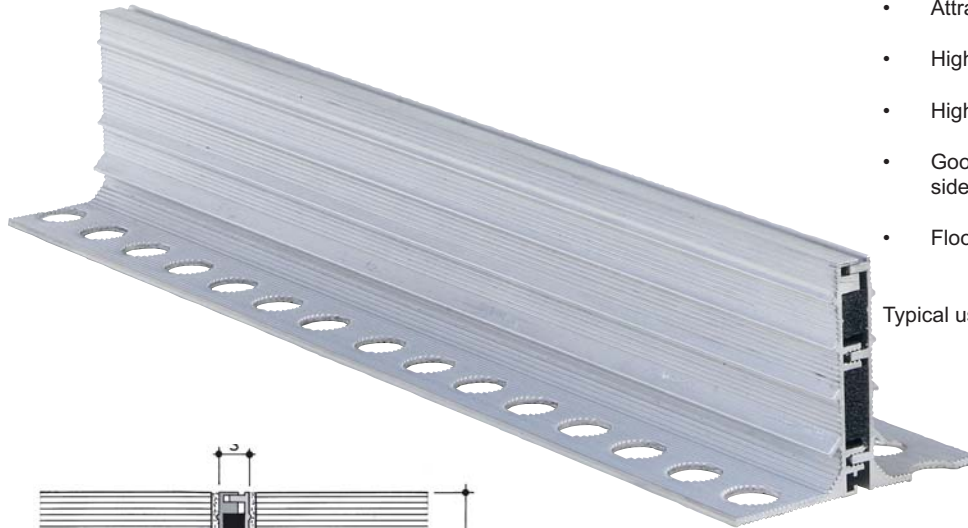

Features:

- Attractive finish, aluminium construction.
- High edge protection
- High load bearing capacity,
- Good key to mortar through graded aluminium side bars.
- Floor to wall versions available.

Typical use: Hard floor finishes
e.g. terrazzo, marble, granite, ceramics

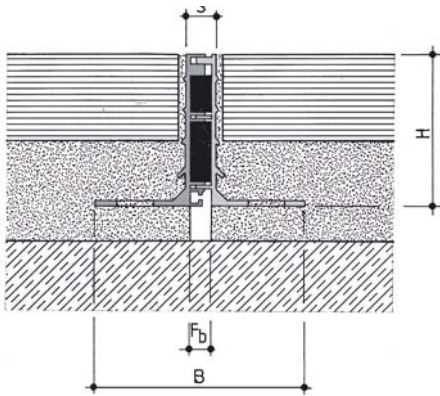

Floor to wall/perimeter profiles available

Profile reference	490/AL
Fb - Joint widths upto (mm)	10mm
H - Heights (mm)	35 or 50 mm
S - Visible width (mm)	10mm
Colours:	Aluminium
Accommodation of movement (mm)	4mm (+/-2mm)
Material	Aluminium, cellular rubber
Load Bearing capacity (kN)	 130kN  600kN
Standard Length	3 metres

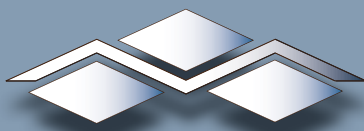

Movement Joints (UK) Ltd,
 Unit 3, 57 Thorby Avenue, March, Cambridgeshire PE15 0AZ United Kingdom
 Tel: 01354 60 79 60 Fax: 01354 60 78 33
 Web: www.mjuk.co.uk e-mail: info@mjuk.co.uk

IMPORTANT: Whilst all reasonable care is taken in compiling technical data on the company's products, all recommendations or suggestions regarding the use of such products are made without guarantee since the conditions of use are beyond the company. It is the customers responsibility to satisfy himself that each product is fit for the purpose for which he intends to use it and that the actual conditions of use are suitable.